



Appendix B1
Site Location Plan



BUSCONNECTS DUBLIN CORE BUS CORRIDORS INFRASTRUCTURE WORKS

TALLAGHT/CLONDALKIN TO CITY CENTRE CORE BUS CORRIDOR SCHEME

SITE LOCATION	
DRAWING SERIES NUMBER(S)	DRAWING SERIES DESCRIPTION
BCIDA-ACM-SPW_IX-0809_XX_00-DR-CR-0001	TALLAGHT/CLONDALKIN TO CITY CENTRE CORE BUS CORRIDOR SCHEME. SITE LOCATION MAP AND PLAN. COVER SHEET
BCIDA-ACM-SPW_KP-0809_XX_00-DR-CR-0001	TALLAGHT/CLONDALKIN TO CITY CENTRE CORE BUS CORRIDOR SCHEME. SITE LOCATION MAP
BCIDA-ACM-SPW_ZZ-0809_XX_00-DR-CR-0001 to 0008	TALLAGHT/CLONDALKIN TO CITY CENTRE CORE BUS CORRIDOR SCHEME. SITE LOCATION PLAN

C:\Users\andrew.bingham\OneDrive - AECOM\Documents\Tallaght Planning Phase\Site location\BCIDA-ACM-SPW_IX-0809_XX_00-DR-CR-0001.dwg

Disclaimer

a. © National Transport Authority (NTA) 2023. This drawing is confidential and the copyright in it is owned by NTA. This drawing must not be either loaned, copied or otherwise reproduced in whole or in part or used for any purpose without the prior permission of NTA.

b. This drawing is to be used for the design element identified in the titlebox. Other information shown is to be considered indicative only. The drawing is to be read in conjunction with all other relevant design drawings.

c. O.S. data used for plans are printed under © Ordnance Survey Ireland Government of Ireland. All rights reserved. Licence Number 2023/OSI_NMA_180 National Transport Authority. All elevations are in metres and relate to OSI Geoid Model (OSGM15) Mean Head. All Co-ordinates are in Irish Transverse Mercator Grid (ITM) as defined by OSI active local GPS station.

d. Information concerning the position of apparatus shown on this drawing is based on drawings supplied by the utility owners and/or the utility works contractor, whilst every care has been taken in the preparation of this drawing, positions should be taken as approximate and are intended for general guidance only and no representation is made by the NTA as to the accuracy, completeness, sufficiency or otherwise of this drawing and the position of the apparatus. The information contained herein does not purport to be comprehensive or final as the apparatus is subject to being altered and/or superceded. Recipients should not rely on this information. Any liabilities are hereby expressly disclaimed.

e. The information contained herein has been provided by the NTA but does not purport to be comprehensive or final. Recipients should not rely on the information. Neither the NTA nor any of its directors, officers, employees, agents, stakeholders or advisers make any representation or warranty as to, or accept any liability or responsibility in relation to, the adequacy, accuracy, reasonableness or completeness of the information provided as part of this document or any matter on which the information is based (including but not limited to loss or damage arising as a result of reliance by recipients on the information or any part of it). Any liabilities are hereby expressly disclaimed.



Rev	Date	Drn	Chk'd	App'd	Description
M01	21/03/23	EM	AD	CA	ISSUE FOR PHASE 4: PLANNING

<p>Údarás Náisiúnta Iompair National Transport Authority</p>			
Date	Scale	Drawn	Checked
21/03/23	N/A @ A1 N/A @ A3	E.MINCHER	A.DUGGAN
Project Code	Originator Code	QMS Code	
BCIDA	ACM		

Programme Title BUSCONNECTS DUBLIN CORE BUS CORRIDORS INFRASTRUCTURE WORKS			
Drawing Title TALLAGHT/CLONDALKIN TO CITY CENTRE CORE BUS CORRIDOR SCHEME SITE LOCATION MAP AND SITE LOCATION PLAN COVER SHEET			
Drawing File Name	Sheet Number	Status	Rev
BCIDA-ACM-SPW_IX-0809_XX_00-DR-CR-0001	01 of 01	A	M01

DO NOT SCALE USE FIGURED DIMENSIONS ONLY

LEGEND:

SITE EXTENTS

SHEET 02
SHEET 01

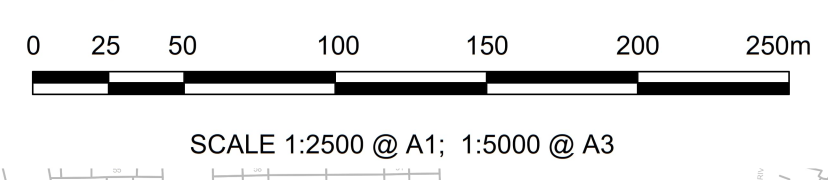
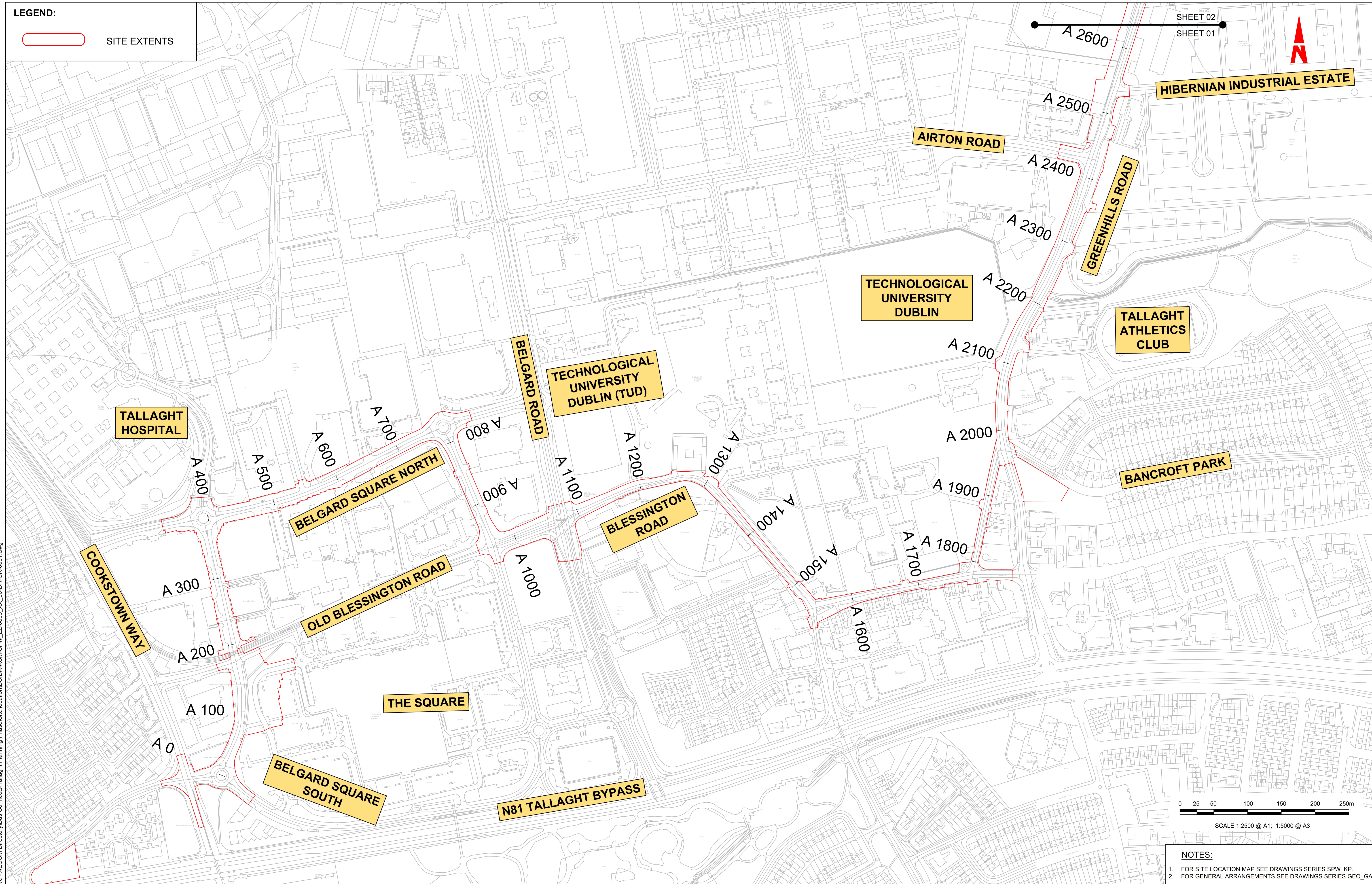

- NOTES:**
- FOR SITE LOCATION MAP SEE DRAWINGS SERIES SPW_KP.
 - FOR GENERAL ARRANGEMENTS SEE DRAWINGS SERIES GEO_GA.

Disclaimer

a. © National Transport Authority (NTA) 2023. This drawing is confidential and the copyright in it is owned by NTA. This drawing must not be either loaned, copied or otherwise reproduced in whole or in part or used for any purpose without the prior permission of NTA.

b. This drawing is to be used for the design element identified in the titlebox. Other information shown is to be considered indicative only. The drawing is to be read in conjunction with all other relevant design drawings.

c. O.S. data used for plans are printed under © Ordnance Survey Ireland Government of Ireland. All rights reserved. Licence Number 2023/OSI_NMA_180 National Transport Authority. All elevations are in metres and relate to OSI Geoid Model (OSGM15) Mean Head. All Co-ordinates are in Irish Transverse Mercator Grid (ITM) as defined by OSI active local GPS station.

d. Information concerning the position of apparatus shown on this drawing is based on drawings supplied by the utility owners and/or the utility works contractor, whilst every care has been taken in the preparation of this drawing, positions should be taken as approximate and are intended for general guidance only and no representation is made by the NTA as to the accuracy, completeness, sufficiency or otherwise of this drawing and the position of the apparatus. The information contained herein does not purport to be comprehensive or final as the apparatus is subject to being altered and/or superceded. Recipients should not rely on this information. Any liabilities are hereby expressly disclaimed.

e. The information contained herein has been provided by the NTA but does not purport to be comprehensive or final. Recipients should not rely on the information. Neither the NTA nor any of its directors, officers, employees, agents, stakeholders or advisers make any representation or warranty as to, or accept any liability or responsibility in relation to, the adequacy, accuracy, reasonableness or completeness of the information provided as part of this document or any matter on which the information is based (including but not limited to loss or damage arising as a result of reliance by recipients on the information or any part of it). Any liabilities are hereby expressly disclaimed.



Rev	Date	Drn	Chk'd	App'd	Description
M01	21/03/23	EM	AD	CA	ISSUE FOR PHASE 4: PLANNING

Client: **NTA**
Udarás Náisiúnta Iompair
National Transport Authority

Engineering Designer: **AECOM** **MOTT MACDONALD**

Date: 21/03/23
Scale: 1:2500 @ A1, 1:5000 @ A3

Project Code: BCIDA
Originator Code: ACM

Drawn: E.MINCHER
Checked: A.DUGGAN
Approved: C.ACTON

QMS Code:

Programme Title: BUSCONNECTS DUBLIN CORE BUS CORRIDORS INFRASTRUCTURE WORKS			
Drawing Title: TALLAGHT/CLONDALKIN TO CITY CENTRE CORE BUS CORRIDOR SCHEME SITE LOCATION PLAN			
Drawing File Name: BCIDA-ACM-SPW_ZZ-0809_XX_00-DR-CR-0001	Sheet Number: 01 of 08	Status: A	Rev: M01

DO NOT SCALE USE FIGURED DIMENSIONS ONLY

C:\Users\andrew.bingham\OneDrive - AECOM\Documents\Tallaght Planning Phase\Site location\BCIDA-ACM-SPW_ZZ-0809_XX_00-DR-CR-0001.dwg

LEGEND:

 SITE EXTENTS

SHEET 03

SHEET 02

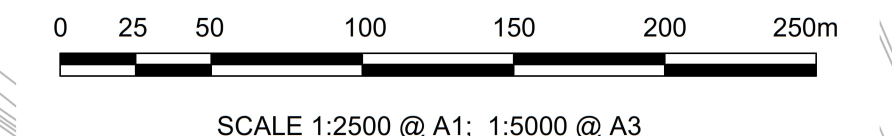
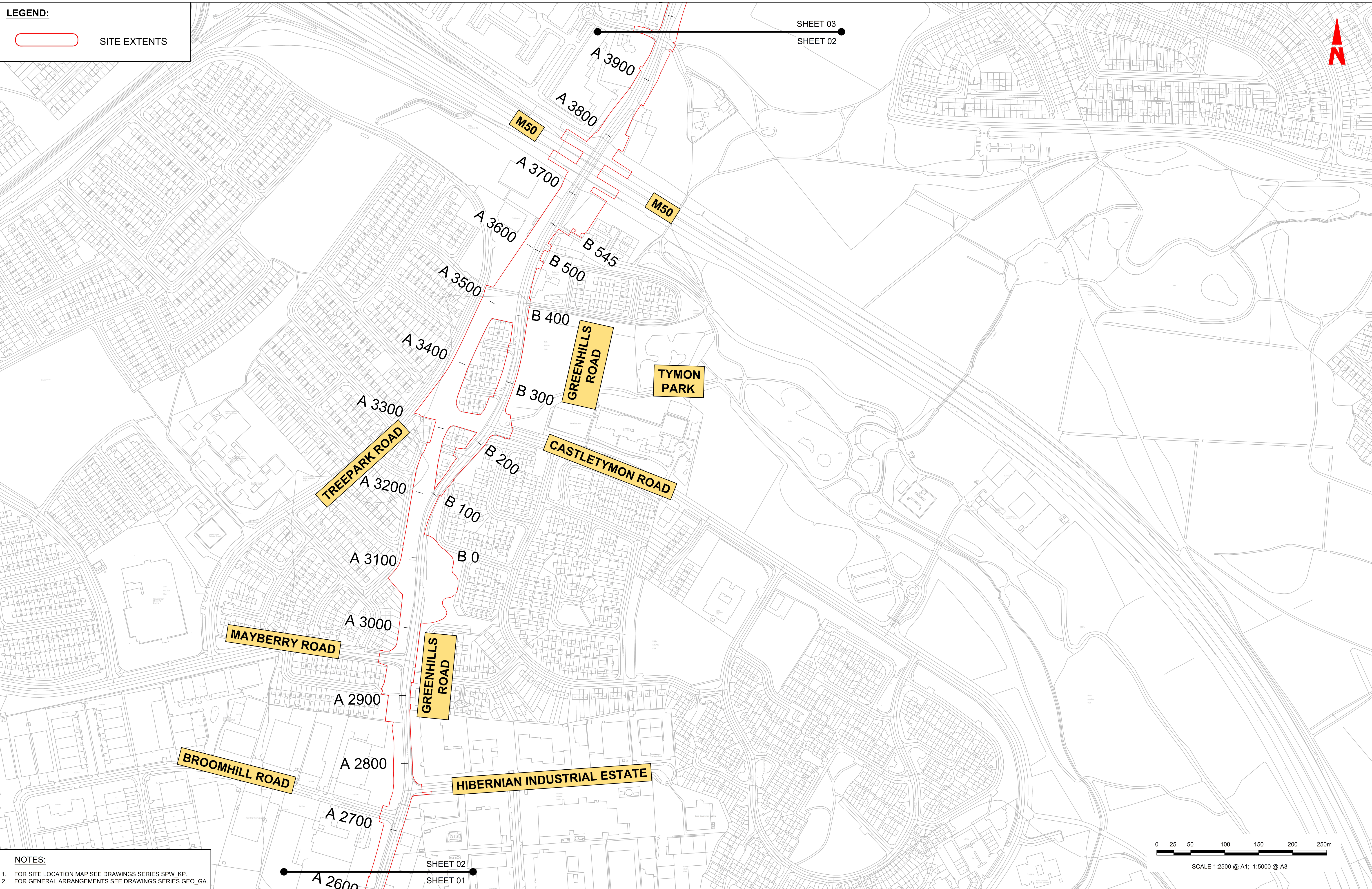

SCALE 1:2500 @ A1; 1:5000 @ A3

NOTES:

- FOR SITE LOCATION MAP SEE DRAWINGS SERIES SPW_KP.
- FOR GENERAL ARRANGEMENTS SEE DRAWINGS SERIES GEO_GA.

Disclaimer

a. © National Transport Authority (NTA) 2023. This drawing is confidential and the copyright in it is owned by NTA. This drawing must not be either loaned, copied or otherwise reproduced in whole or in part or used for any purpose without the prior permission of NTA.

b. This drawing is to be used for the design element identified in the titlebox. Other information shown is to be considered indicative only. The drawing is to be read in conjunction with all other relevant design drawings.



c. O.S. data used for plans are printed under © Ordnance Survey Ireland Government of Ireland. All rights reserved. Licence Number 2023/OSI_NMA_180 National Transport Authority. All elevations are in metres and relate to OSI Geoid Model (OSGM15) Mean Head. All Co-ordinates are in Irish Transverse Mercator Grid (ITM) as defined by OSI active local GPS station.

d. Information concerning the position of apparatus shown on this drawing is based on drawings supplied by the utility owners and/or the utility works contractor, whilst every care has been taken in the preparation of this drawing, positions should be taken as approximate and are intended for general guidance only and no representation is made by the NTA as to the accuracy, completeness, sufficiency or otherwise of this information or any part of it. Any liabilities are hereby expressly disclaimed.

e. The information contained herein has been provided by the NTA but does not purport to be comprehensive or final. Recipients should not rely on the information. Neither the NTA nor any of its directors, officers, employees, agents, stakeholders or advisers make any representation or warranty as to, or accept any liability or responsibility in relation to, the adequacy, accuracy, reasonableness or completeness of the information provided as part of this document or any matter on which the information is based (including but not limited to loss or damage arising as a result of reliance by recipients on the information or any part of it). Any liabilities are hereby expressly disclaimed.



Rev	Date	Drn	Chk'd	App'd	Description
M01	21/03/23	EM	AD	CA	ISSUE FOR PHASE 4: PLANNING

 Údarás Náisiúnta Iompair National Transport Authority		Engineering Designer  		
Date	Scale	Drawn	Checked	Approved
21/03/23	1:2500 @ A1 1:5000 @ A3	E.MINCHER	A.DUGGAN	C.ACTON
Project Code	Originator Code	QMS Code		
BCIDA	ACM			

Programme Title BUSCONNECTS DUBLIN CORE BUS CORRIDORS INFRASTRUCTURE WORKS			
Drawing Title TALLAGHT/CLONDALKIN TO CITY CENTRE CORE BUS CORRIDOR SCHEME SITE LOCATION PLAN			
Drawing File Name	Sheet Number	Status	Rev
BCIDA-ACM-SPW_ZZ-0809_XX_00-DR-CR-0002	02 of 08	A	M01

DO NOT SCALE USE FIGURED DIMENSIONS ONLY

C:\Users\andrew.bingham\OneDrive - AECOM\Documents\Tallaght Planning Phase\Site location\BCIDA-ACM-SPW_ZZ-0809_XX_00-DR-CR-0002.dwg

LEGEND:

 SITE EXTENTS

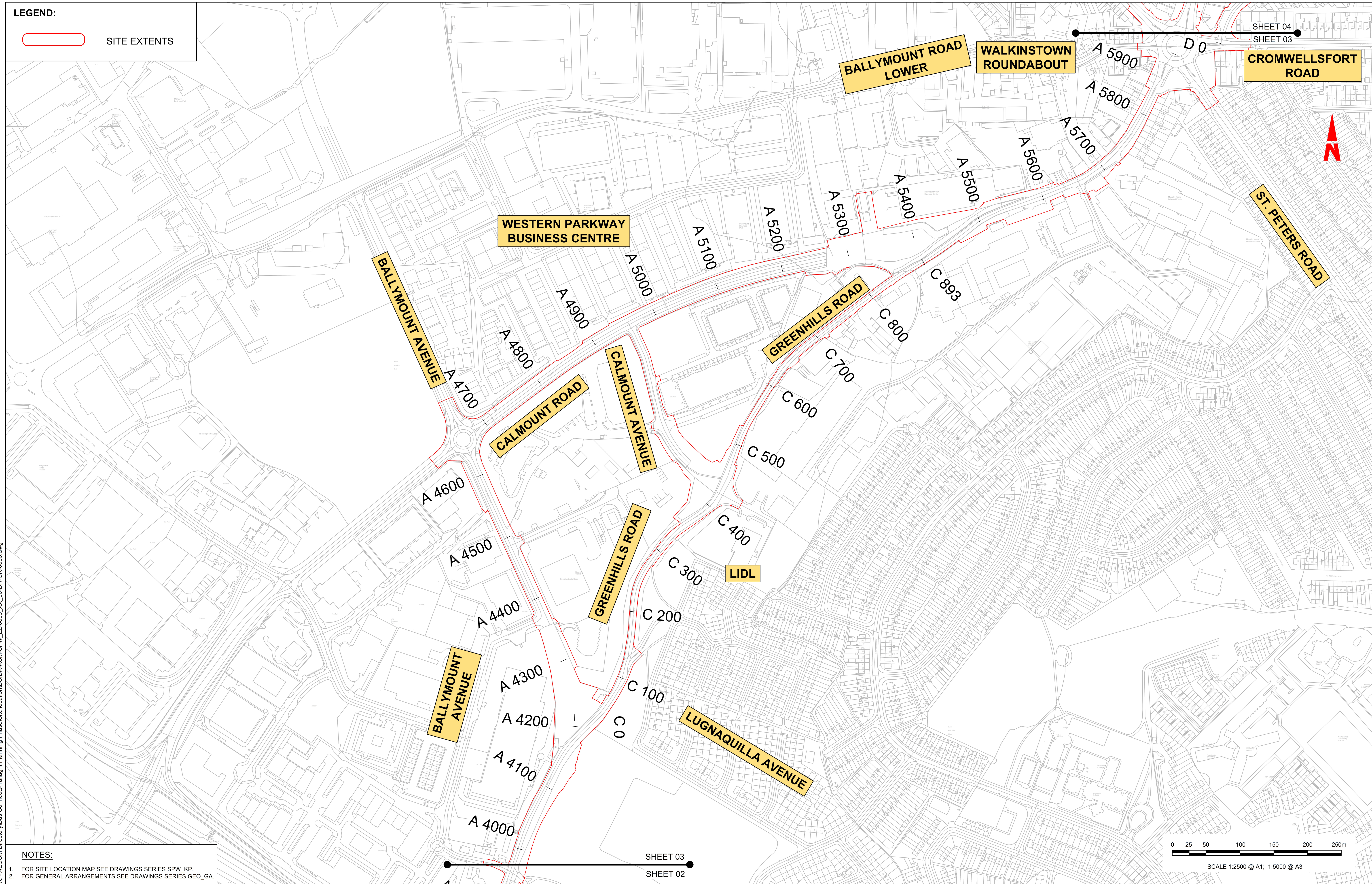

- NOTES:**
- FOR SITE LOCATION MAP SEE DRAWINGS SERIES SPW_KP.
 - FOR GENERAL ARRANGEMENTS SEE DRAWINGS SERIES GEO_GA.

Disclaimer

a. © National Transport Authority (NTA) 2023. This drawing is confidential and the copyright in it is owned by NTA. This drawing must not be either loaned, copied or otherwise reproduced in whole or in part or used for any purpose without the prior permission of NTA.

b. This drawing is to be used for the design element identified in the titlebox. Other information shown is to be considered indicative only. The drawing is to be read in conjunction with all other relevant design drawings.

c. O.S. data used for plans are printed under © Ordnance Survey Ireland Government of Ireland. All rights reserved. Licence Number 2023/OSI_NMA_180 National Transport Authority. All elevations are in metres and relate to OSI Geoid Model (OSGM15) Mean Head. All Co-ordinates are in Irish Transverse Mercator Grid (ITM) as defined by OSI active local GPS station.

d. Information concerning the position of apparatus shown on this drawing is based on drawings supplied by the utility owners and/or the utility works contractor, whilst every care has been taken in the preparation of this drawing, positions should be taken as approximate and are intended for general guidance only and no representation is made by the NTA as to the accuracy, completeness, sufficiency or otherwise of this drawing and the position of the apparatus. The information contained herein does not purport to be comprehensive or final as the apparatus is subject to being altered and/or superseded. Recipients should not rely on this information. Any liabilities are hereby expressly disclaimed.

e. The information contained herein has been provided by the NTA but does not purport to be comprehensive or final. Recipients should not rely on the information. Neither the NTA nor any of its directors, officers, employees, agents, stakeholders or advisers make any representation or warranty as to, or accept any liability or responsibility in relation to, the adequacy, accuracy, reasonableness or completeness of the information provided as part of this document or any matter on which the information is based (including but not limited to loss or damage arising as a result of reliance by recipients on the information or any part of it). Any liabilities are hereby expressly disclaimed.



Project Ireland 2040
Building Ireland's Future

Rev	Date	Drn	Chk'd	App'd	Description
M01	21/03/23	EM	AD	CA	ISSUE FOR PHASE 4: PLANNING

Client: **NTA**
Udarás Náisiúnta Iompair
National Transport Authority

Date: 21/03/23

Scale: 1:2500 @ A1
1:5000 @ A3

Project Code: BCIDA
Originator Code: ACM

Engineering Designer: **AECOM** **MOTT MACDONALD**

Drawn: E.MINCHER
Checked: A.DUGGAN
Approved: C.ACTON

Programme Title: **BUSCONNECTS DUBLIN CORE BUS CORRIDORS INFRASTRUCTURE WORKS**

Drawing Title: TALLAGHT/CLONDALKIN TO CITY CENTRE CORE BUS CORRIDOR SCHEME SITE LOCATION PLAN

Drawing File Name: BCIDA-ACM-SPW_ZZ-0809_XX_00-DR-CR-0003

Sheet Number: 03 of 08

Status: A

Rev: M01

DO NOT SCALE USE FIGURED DIMENSIONS ONLY

C:\Users\andrew.bingham\OneDrive - AECOM\Documents\Tallaght Planning Phase4\Site location\BCIDA-ACM-SPW_ZZ-0809_XX_00-DR-CR-0003.dwg

LEGEND:

 SITE EXTENTS

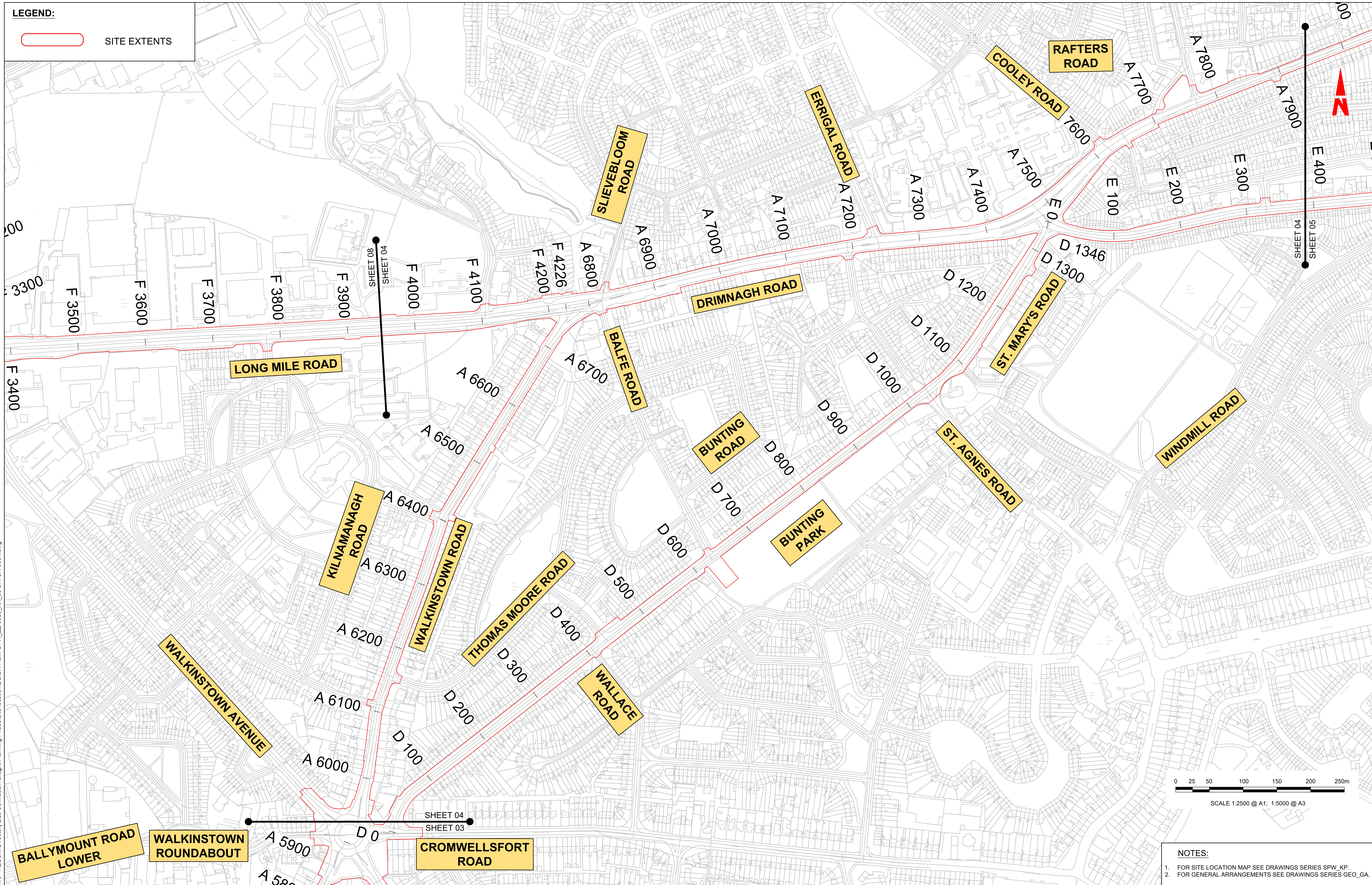

0 25 50 100 150 200 250m
SCALE 1:2500 @ A1; 1:5000 @ A3

- NOTES:**
- FOR SITE LOCATION MAP SEE DRAWINGS SERIES SPW_KP.
 - FOR GENERAL ARRANGEMENTS SEE DRAWINGS SERIES GEO_GA.

Disclaimer
 a. © National Transport Authority (NTA) 2023. This drawing is confidential and the copyright in it is owned by NTA. This drawing must not be either loaned, copied or otherwise reproduced in whole or in part or used for any purpose without the prior permission of NTA.
 b. This drawing is to be used for the design element identified in the title block. Other information shown is to be considered indicative only. The drawing is to be read in conjunction with all other relevant design drawings.
 c. O.S. data used for plans are printed under © Ordnance Survey Ireland Government of Ireland. All rights reserved. Licence Number 2023/OSI_NMA_180 National Transport Authority. All elevations are in metres and relate to OSi Geoid Model (OSGM15) Mean Head. All Co-ordinates are in Irish.

Transverse Mercator Grid (ITM) as defined by OSI active local GPS station.
 d. Information concerning the position of apparatus shown on this drawing is based on drawings supplied by the utility owners and/or the utility works contractor, whilst every care has been taken in the preparation of this drawing, positions should be taken as approximate and are intended for general guidance only and no representation is made by the NTA as to the accuracy, completeness, sufficiency or otherwise of this drawing and the position of the apparatus. The information contained herein does not purport to be comprehensive or final as the apparatus is subject to being altered and/or superceded. Recipients should not rely on this information. Any liabilities are hereby expressly disclaimed.

The information contained herein has been provided by the NTA but does not purport to be comprehensive or final. Recipients should not rely on the information. Neither the NTA nor any of its directors, officers, employees, agents, stakeholders or advisers make any representation or warranty as to, or accept any liability or responsibility in relation to, the adequacy, accuracy, reasonableness or completeness of the information provided as part of this document or any matter on which the information is based (including but not limited to loss or damage arising as a result of reliance by recipients on the information or any part of it). Any liabilities are hereby expressly disclaimed.



Project Ireland 2040
Building Ireland's Future

Rev	Date	Drn	Chk'd	App'd	Description
M01	21/03/23	EM	AD	CA	ISSUE FOR PHASE 4: PLANNING

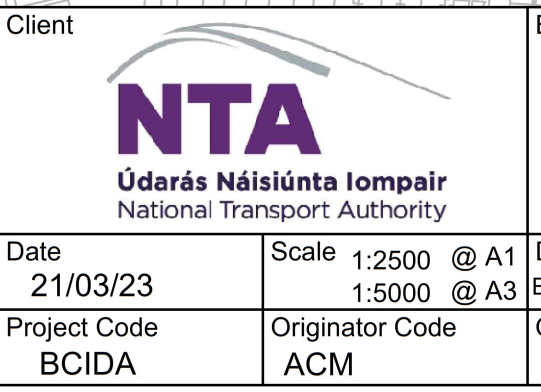
Client

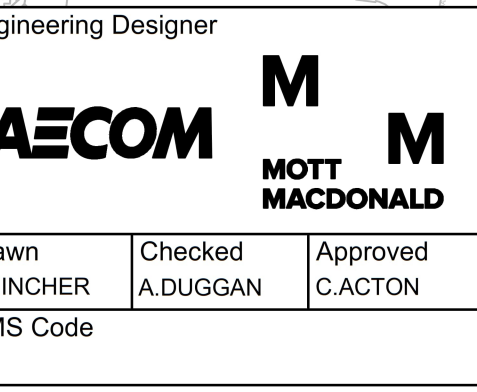
 Údarás Náisiúnta Iompair
 National Transport Authority

Engineering Designer

 MOTT MACDONALD

Programme Title BUSCONNECTS DUBLIN CORE BUS CORRIDORS INFRASTRUCTURE WORKS			
Drawing Title TALLAGHT/CLONDALKIN TO CITY CENTRE CORE BUS CORRIDOR SCHEME SITE LOCATION PLAN			
Drawing File Name BCIDA-ACM-SPW_ZZ-0809_XX_00-DR-CR-0004	Sheet Number 04 of 08	Status A	Rev M01

DO NOT SCALE USE FIGURED DIMENSIONS ONLY

C:\Users\andrew.bingham\OneDrive - AECOM\Documents\Tallaght Planning Phase\Site location\BCIDA-ACM-SPW_ZZ-0809_XX_00-DR-CR-0004.dwg

LEGEND:

 SITE EXTENTS

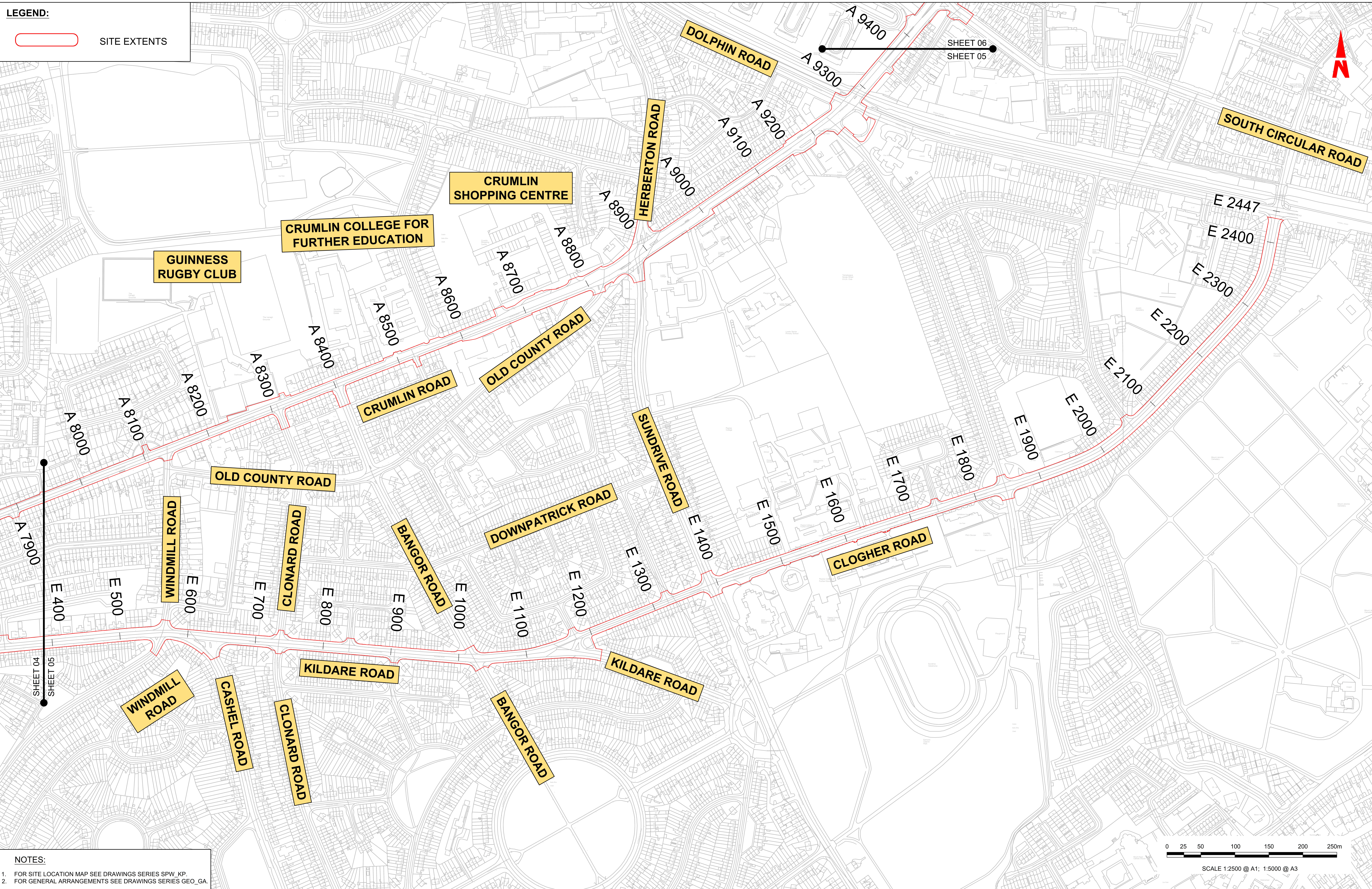

- NOTES:**
- FOR SITE LOCATION MAP SEE DRAWINGS SERIES SPW_KP.
 - FOR LOCATION ARRANGEMENTS SEE DRAWINGS SERIES GEO_GA.

Disclaimer

a. © National Transport Authority (NTA) 2023. This drawing is confidential and the copyright in it is owned by NTA. This drawing must not be either loaned, copied or otherwise reproduced in whole or in part or used for any purpose without the prior permission of NTA.

b. This drawing is to be used for the design element identified in the title block. Other information shown is to be considered indicative only. The drawing is to be read in conjunction with all other relevant design drawings.

c. O.S. data used for plans are printed under © Ordnance Survey Ireland Government of Ireland. All rights reserved. Licence Number 2023/OSI_NMA_180 National Transport Authority. All elevations are in metres and relate to OSI Geoid Model (OSGM15) Mean Head. All Co-ordinates are in Irish Transverse Mercator Grid (ITM) as defined by OSI active local GPS station.

d. Information concerning the position of apparatus shown on this drawing is based on drawings supplied by the utility owners and/or the utility works contractor, whilst every care has been taken in the preparation of this drawing, positions should be taken as approximate and are intended for general guidance only and no representation is made by the NTA as to the accuracy, completeness, sufficiency or otherwise of this drawing and the position of the apparatus. The information contained herein does not purport to be comprehensive or final as the apparatus is subject to being altered and/or superseded. Recipients should not rely on this information. Any liabilities are hereby expressly disclaimed.

e. The information contained herein has been provided by the NTA but does not purport to be comprehensive or final. Recipients should not rely on the information. Neither the NTA nor any of its directors, officers, employees, agents, stakeholders or advisers make any representation or warranty as to, or accept any liability or responsibility in relation to, the adequacy, accuracy, reasonableness or completeness of the information provided as part of this document or any matter on which the information is based (including but not limited to loss or damage arising as a result of reliance by recipients on the information or any part of it). Any liabilities are hereby expressly disclaimed.



Rev	Date	Drn	Chk'd	App'd	Description
M01	21/03/23	EM	AD	CA	ISSUE FOR PHASE 4: PLANNING

Client: **NTA**
Údarás Náisiúnta Iompair
National Transport Authority

Date: 21/03/23

Scale: 1:2500 @ A1
1:5000 @ A3

Engineering Designer: **AECOM** **MOTT MACDONALD**

Drawn: E.MINCHER
Checked: A.DUGGAN
Approved: C.ACTON

Project Code: BCIDA
Originator Code: ACM

QMS Code:

Programme Title: **BUSCONNECTS DUBLIN**
CORE BUS CORRIDORS INFRASTRUCTURE WORKS

Drawing Title: TALLAGHT/CLONDALKIN TO CITY CENTRE CORE BUS CORRIDOR SCHEME
SITE LOCATION PLAN

Drawing File Name: BCIDA-ACM-SPW_ZZ-0809_XX_00-DR-CR-0005

Sheet Number: 05 of 08

Status: A

Rev: M01

DO NOT SCALE USE FIGURED DIMENSIONS ONLY

C:\Users\andrew.bingham\OneDrive - AECOM\Documents\Tallaght Planning Phase\Site location\BCIDA-ACM-SPW_ZZ-0809_XX_00-DR-CR-0005.dwg

LEGEND:

 SITE EXTENTS

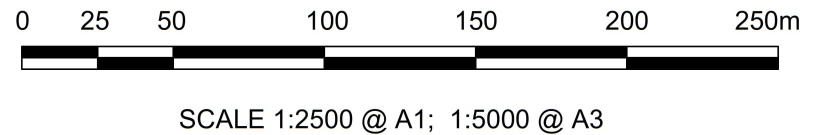
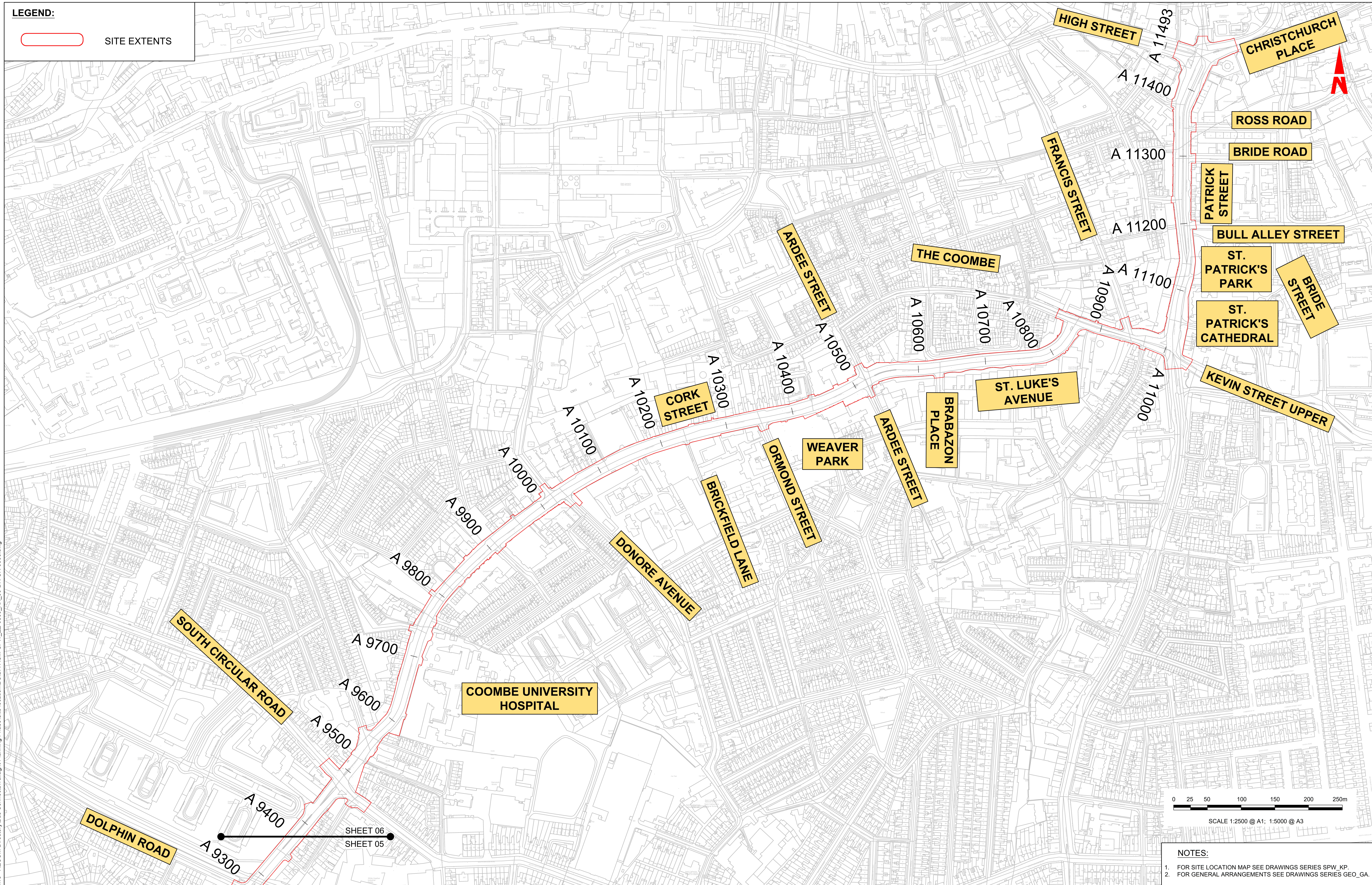

- NOTES:**
- FOR SITE LOCATION MAP SEE DRAWINGS SERIES SPW_KP.
 - FOR GENERAL ARRANGEMENTS SEE DRAWINGS SERIES GEO_GA.

Disclaimer
a. © National Transport Authority (NTA) 2023. This drawing is confidential and the copyright in it is owned by NTA. This drawing must not be either loaned, copied or otherwise reproduced in whole or in part or used for any purpose without the prior permission of NTA.
b. This drawing is to be used for the design element identified in the title block. Other information shown is to be considered indicative only. The drawing is to be read in conjunction with all other relevant design drawings.
c. O.S. data used for plans are printed under © Ordnance Survey Ireland Government of Ireland. All rights reserved. Licence Number 2023/OSI_NMA_180 National Transport Authority. All elevations are in metres and relate to OSI Geoid Model (OSGM15) Mean Head. All Co-ordinates are in Irish Transverse Mercator Grid (ITM) as defined by OSI active local GPS station.
d. Information concerning the position of apparatus shown on this drawing is based on drawings supplied by the utility owners and/or the utility works contractor, whilst every care has been taken in the preparation of this drawing, positions should be taken as approximate and are intended for general guidance only and no representation is made by the NTA as to the accuracy, completeness, sufficiency or otherwise of this drawing and the position of the apparatus. The information contained herein does not purport to be comprehensive or final as the apparatus is subject to being altered and/or superceded. Recipients should not rely on this information. Any liabilities are hereby expressly disclaimed.
e. The information contained herein has been provided by the NTA but does not purport to be comprehensive or final. Recipients should not rely on the information. Neither the NTA nor any of its directors, officers, employees, agents, stakeholders or advisers make any representation or warranty as to, or accept any liability or responsibility in relation to, the adequacy, accuracy, reasonableness or completeness of the information provided as part of this document or any matter on which the information is based (including but not limited to loss or damage arising as a result of reliance by recipients on the information or any part of it). Any liabilities are hereby expressly disclaimed.

Project Ireland 2040
Building Ireland's Future

Rev	Date	Drn	Chk'd	App'd	Description
M01	21/03/23	EM	AD	CA	ISSUE FOR PHASE 4: PLANNING

Client: **NTA**
Údarás Náisiúnta Iompair
National Transport Authority

Engineering Designer: **AECOM** **MOTT MACDONALD**

Date: 21/03/23
Scale: 1:2500 @ A1, 1:5000 @ A3

Project Code: BCIDA
Originator Code: ACM

Drawn: E.MINCHER
Checked: A.DUGGAN
Approved: C.ACTON

QMS Code:

Programme Title BUSCONNECTS DUBLIN CORE BUS CORRIDORS INFRASTRUCTURE WORKS			
Drawing Title TALLAGHT/CLONDALKIN TO CITY CENTRE CORE BUS CORRIDOR SCHEME SITE LOCATION PLAN			
Drawing File Name BCIDA-ACM-SPW_ZZ-0809_XX_00-DR-CR-0006	Sheet Number 06 of 08	Status A	Rev M01

DO NOT SCALE USE FIGURED DIMENSIONS ONLY

C:\Users\andrew.bingham\OneDrive - AECOM\Documents\Tallaght Planning Phase\Site location\BCIDA-ACM-SPW_ZZ-0809_XX_00-DR-CR-0006.dwg

LEGEND:

 SITE EXTENTS

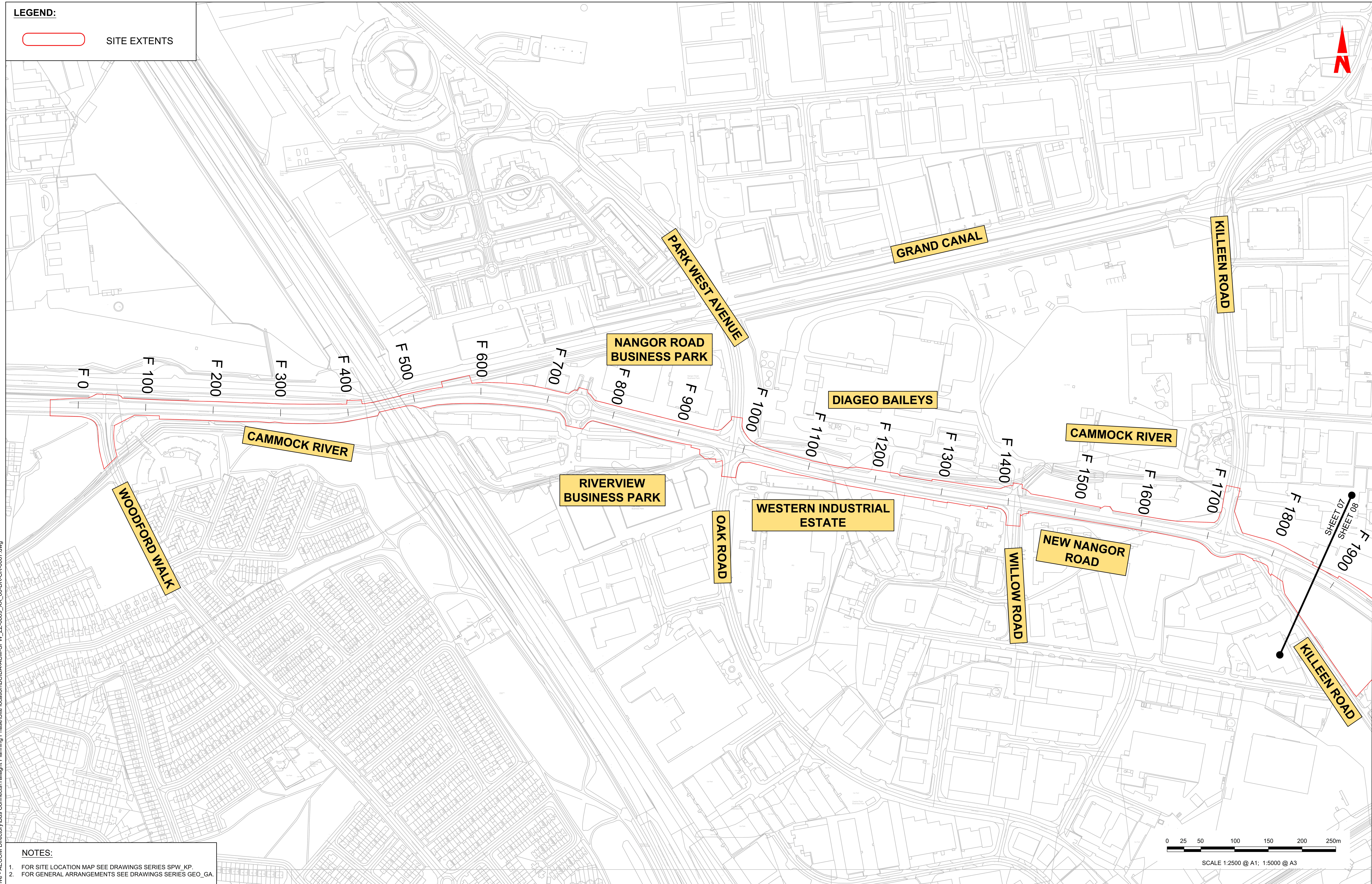

NOTES:

- FOR SITE LOCATION MAP SEE DRAWINGS SERIES SPW_KP.
- FOR GENERAL ARRANGEMENTS SEE DRAWINGS SERIES GEO_GA.

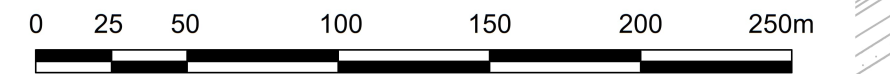

SCALE 1:2500 @ A1; 1:5000 @ A3

Disclaimer

a. © National Transport Authority (NTA) 2023. This drawing is confidential and the copyright in it is owned by NTA. This drawing must not be either loaned, copied or otherwise reproduced in whole or in part or used for any purpose without the prior permission of NTA.

b. This drawing is to be used for the design element identified in the titlebox. Other information shown is to be considered indicative only. The drawing is to be read in conjunction with all other relevant design drawings.

c. D.S. data used for plans are printed under © Ordnance Survey Ireland Government of Ireland. All rights reserved. Licence Number 2023/OSI_NMA_180 National Transport Authority. All elevations are in metres and relate to OSI Geoid Model (OSGM15) Mean Head. All Co-ordinates are in Irish Transverse Mercator Grid (ITM) as defined by OSI active local GPS station.

d. Information concerning the position of apparatus shown on this drawing is based on drawings supplied by the utility owners and/or the utility works contractor, whilst every care has been taken in the preparation of this drawing, positions should be taken as approximate and are intended for general guidance only and no representation is made by the NTA as to the accuracy, completeness, sufficiency or otherwise of this drawing and the position of the apparatus. The information contained herein does not purport to be comprehensive or final as the apparatus is subject to being altered and/or superseded. Recipients should not rely on this information. Any liabilities are hereby expressly disclaimed.



e. The information contained herein has been provided by the NTA but does not purport to be comprehensive or final. Recipients should not rely on the information. Neither the NTA nor any of its directors, officers, employees, agents, stakeholders or advisers make any representation or warranty as to, or accept any liability or responsibility in relation to, the adequacy, accuracy, reasonableness or completeness of the information provided as part of this document or any matter on which the information is based (including but not limited to loss or damage arising as a result of reliance by recipients on the information or any part of it). Any liabilities are hereby expressly disclaimed.



Project Ireland 2040
Building Ireland's Future

Rev	Date	Drm	Chk'd	App'd	Description
M01	21/03/23	EM	AD	CA	ISSUE FOR PHASE 4: PLANNING

Client:  **Údarás Náisiúnta Iompair**
National Transport Authority

Engineering Designer:  **AECOM**  **MOTT MACDONALD**

Date: 21/03/23
Scale: 1:2500 @ A1, 1:5000 @ A3
Project Code: BCIDA, ACM
Drawn: E.MINCHER, Checked: A.DUGGAN, Approved: C.ACTON
QMS Code:

Programme Title: BUSCONNECTS DUBLIN CORE BUS CORRIDORS INFRASTRUCTURE WORKS			
Drawing Title: TALLAGHT/CLONDALKIN TO CITY CENTRE CORE BUS CORRIDOR SCHEME SITE LOCATION PLAN			
Drawing File Name: BCIDA-ACM-SPW_ZZ-0809_XX_00-DR-CR-0007	Sheet Number: 07 of 08	Status: A	Rev: M01

DO NOT SCALE USE FIGURED DIMENSIONS ONLY

LEGEND:

 SITE EXTENTS

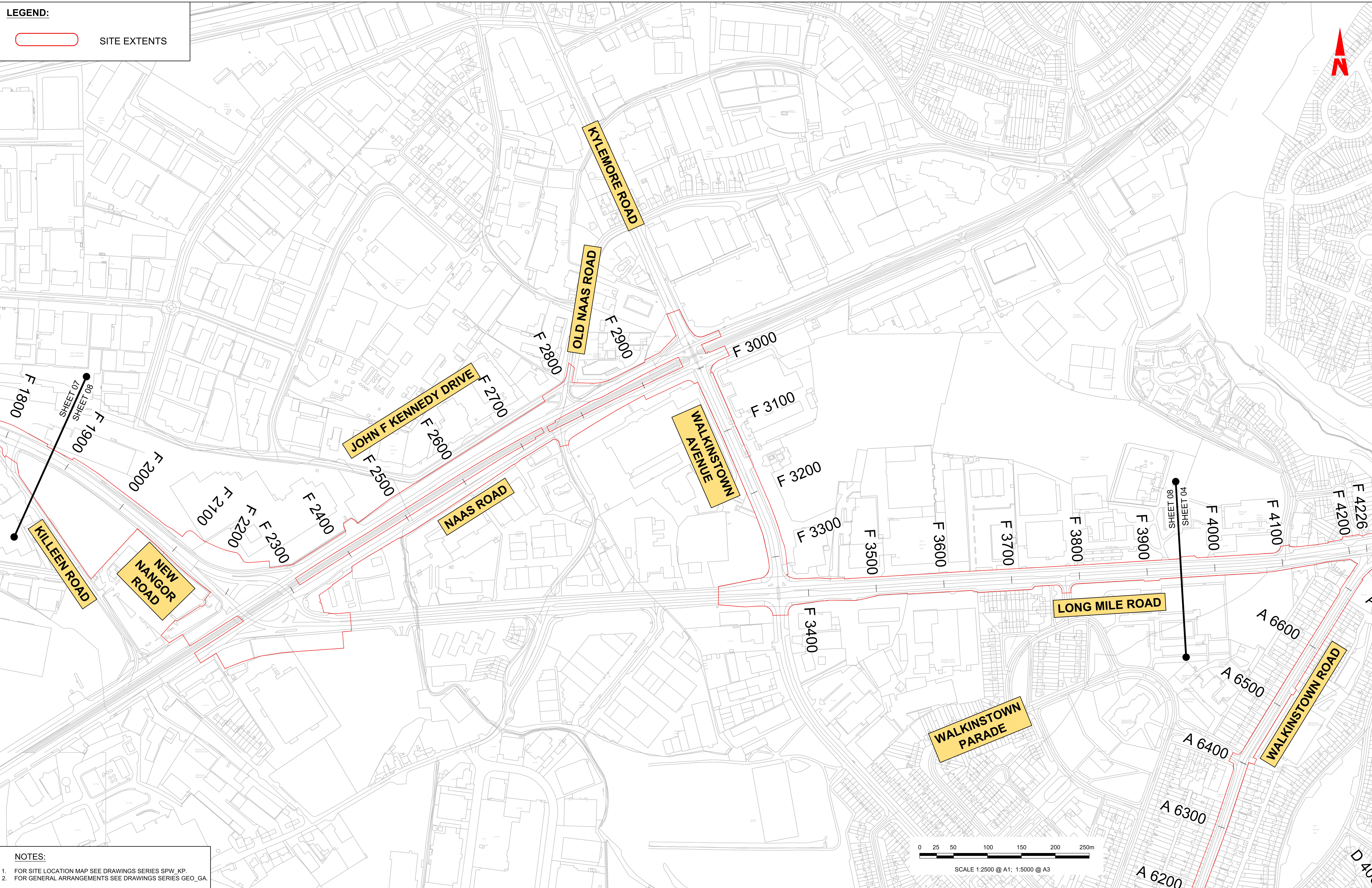

NOTES:



- FOR SITE LOCATION MAP SEE DRAWINGS SERIES SPW_KP.
- FOR GENERAL ARRANGEMENTS SEE DRAWINGS SERIES GEO_GA.

Disclaimer
 a. © National Transport Authority (NTA) 2023. This drawing is confidential and the copyright in it is owned by NTA. This drawing must not be either loaned, copied or otherwise reproduced in whole or in part or used for any purpose without the prior permission of NTA.
 b. This drawing is to be used for the design element identified in the titlebox. Other information shown is to be considered indicative only. The drawing is to be read in conjunction with all other relevant design drawings.
 c. D.S. data used for plans are printed under © Ordnance Survey Ireland Government of Ireland. All rights reserved. Licence Number 2023/OSI_NMA_180 National Transport Authority. All elevations are in metres and relate to OSI Geoid Model (OSGM15) Mean Head. All Co-ordinates are in Irish Transverse Mercator Grid (ITM) as defined by OSI active local GPS station.
 d. Information concerning the position of apparatus shown on this drawing is based on drawings supplied by the utility owners and/or the utility works contractor, whilst every care has been taken in the preparation of this drawing, positions should be taken as approximate and are intended for general guidance only and no representation is made by the NTA as to the accuracy, completeness, sufficiency or otherwise of this drawing and the position of the apparatus. The information contained herein does not purport to be comprehensive or final as the apparatus is subject to being altered and/or superceded. Recipients should not rely on this information. Any liabilities are hereby expressly disclaimed.
 e. The information contained herein has been provided by the NTA but does not purport to be comprehensive or final. Recipients should not rely on the information. Neither the NTA nor any of its directors, officers, employees, agents, stakeholders or advisers make any representation or warranty as to, or accept any liability or responsibility in relation to, the adequacy, accuracy, reasonableness or completeness of the information provided as part of this document or any matter on which the information is based (including but not limited to loss or damage arising as a result of reliance by recipients on the information or any part of it). Any liabilities are hereby expressly disclaimed.



Rev	Date	Drn	Chk'd	App'd	Description
M01	21/03/23	EM	AD	CA	ISSUE FOR PHASE 4: PLANNING

Client

 Údarás Náisiúnta Iompair
 National Transport Authority

Engineering Designer
 
 Drawn E.MINCHER
 Checked A.DUGGAN
 Approved C.ACTON

Programme Title BUSCONNECTS DUBLIN CORE BUS CORRIDORS INFRASTRUCTURE WORKS			
Drawing Title TALLAGHT/CLONDALKIN TO CITY CENTRE CORE BUS CORRIDOR SCHEME SITE LOCATION PLAN			
Drawing File Name BCIDA-ACM-SPW_ZZ-0809_XX_00-DR-CR-0008	Sheet Number 08 of 08	Status A	Rev M01

DO NOT SCALE USE FIGURED DIMENSIONS ONLY